

EXHIBIT DISPLAY RULES AND REGULATIONS

The following Exhibit Display Rules & Regulations are designed to assist you in the construction of your exhibit. Read these guidelines carefully in order to avoid timely and costly delays on show site.

ALL STANDARD (IN-LINE) BOOTHS (any booth that is 10' in depth)
Booth height, including all signage cannot exceed 8'3".

ALL ISLAND BOOTHS

Booth height including all signage cannot exceed 16'. Hanging signs will be allowed, providing they are hung 16' from the floor to the top of the sign. Sign hanging must be arranged through Freeman Decorating.

Standard (in-line) booth

A standard booth is any booth 10' in depth.

Booths 10' in depth may be built to a **height NOT to exceed 8' 3" including any signage.**

The side walls of booths 10' in depth may extend 5' from the back wall at a height of 8'3", then must drop down to a height of 4' as not to block the sight lines of neighboring exhibitors. All solid opaque structures or exhibit materials over 4' in height are to be confined to within 5' of the back wall of the booth to avoid obstructing the view of adjoining exhibitors.

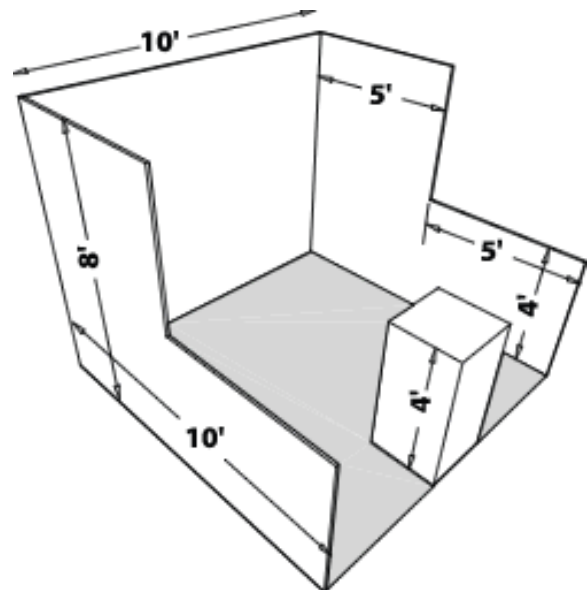

Use of Space

Regardless of the number of Linear Booths utilized, (e.g., 10'x20', 10'x30, 10'x40', etc.) display materials should be arranged in such a manner so as not to obstruct sight lines of neighboring exhibitors. The maximum height of eight feet (8'3") is allowed only in the rear half of the booth space, with a four-foot (4') height restriction imposed on all materials in the remaining space forward to the aisle. (Note: When three or more Linear Booths are used in combination as a single exhibit space, the four-foot (4') height limitation is applied only to that portion of exhibit space which is within ten feet (10') of an adjoining booth.)