



EXHIBIT DISPLAY RULES AND REGULATIONS

The following Exhibit Display Rules & Regulations are designed to assist you in the construction of your exhibit. Read these guidelines carefully in order to avoid timely and costly delays on show site.

ALL STANDARD (IN-LINE) BOOTHS (any booth that is 10' in depth)

- May not exceed 8'3" in height.

ALL ISLAND BOOTHS

- May not exceed 16' in height. Hanging signs will be allowed, providing they are hung 16' from the floor to the top of the sign. Sign hanging must be arranged through Freeman Decorating.

Standard (in-line) booth

A standard in-line (linear) booth is any booth 10' in depth.

In-line booths 10' in depth may not exceed 8'3" in height including identification sign.

The side walls of booths 10' in depth may extend 5' from the back wall at a height of 8', then down to a height of 4' as not to block the sight lines of neighboring exhibitors. All solid opaque structures or exhibit materials over 4' in height are restricted within 5' of the back wall of the booth to avoid obstructing the view of adjoining exhibitors.

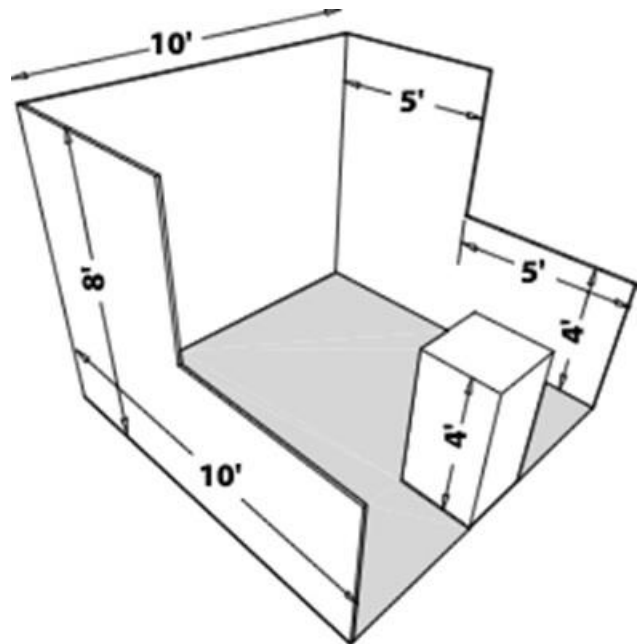

Use of Space

Regardless of the size of the in-line booth (e.g., 10'x20', 10'x30', 10'x40', etc.) **display materials should be arranged as to not obstruct sight lines of neighboring exhibitors.** Maximum height of 8'3" is allowed only in the rear half of the booth space, with a four-foot (4') height restriction on all materials in the remaining space forward to the aisle. Note: When three or more in-line booths are used in combination as a single exhibit space, the four foot (4') height limitation is applied only to that portion of exhibit space which is within ten feet (10') of an adjoining booth.